

Molded Sprockets IMPROVED VERSION

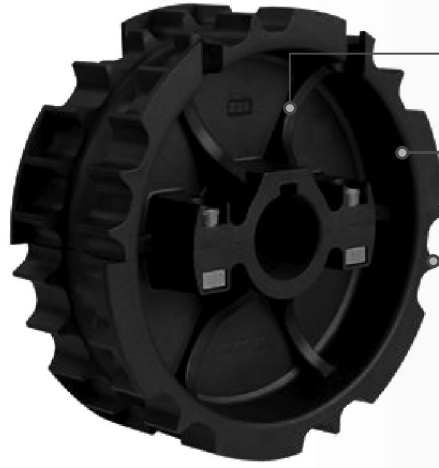

Improved strenght

+30%

New color

The sprocket becomes black.

Superior engagement

A new design improves interaction between chain-sprocket.

**Improved Design
and Performance**

Ingranaggi

L'ingranaggio è uno dei più importanti componenti di un impianto di trasporto. Una ruota ben disegnata assicura una migliore performance e una maggior durata del trasportatore. Offriamo una vasta gamma di ruote fresate e stampate per soddisfare ogni necessità applicativa.

Gli ingranaggi Movex nascono da anni di esperienza specifica ed offriamo la più avanzata soluzione:

1. Tutte le ruote sono concepite in due pezzi per un più facile montaggio/smontaggio sull'albero.
2. Tutte le superfici sono lisce per prevenire qualsiasi deposito.
3. I nostri ingranaggi sono ottenuti dal miglior poliammide per assicurare la più lunga durata e resistenza all'usura.
4. Il profilo del dente è specificamente disegnato per offrire la maggior superficie di contatto con la catena e/o il tappeto riducendo la forza esercitata su ciascun dente consentendo una vita più lunga dell'ingranaggio. Il design è sviluppato inoltre tenendo conto dell'allungamento naturale di catena/tappeto, garantendo agli stessi di performare senza problemi entro la soglia di tolleranza dell'allungamento.
5. Le viti in acciaio inossidabile vengono accoppiate con dadi autobloccanti e/o inserti nichelati per consentire un più facile smontaggio/riasseblaggio anche dopo un lungo periodo dall'installazione.

Sprockets

The sprocket is one of the most important parts of a conveyor. A well designed sprocket will ensure that the conveyor runs smoothly and efficiently for a long time. We have a wide variety of machined and molded sprockets to cover all application needs. Movex Sprockets are designed based on many years of experience to provide you the ultimate solution.

1. All our sprockets are designed split so that it can be installed and uninstalled from the shaft easily.
2. All surfaces and edges from the sprockets are smooth to prevent dirt depositing easily. This makes cleaning easier, maintaining a high hygiene standard.
3. Our sprockets are produced from the best polyamide material to ensure longer wear life.
4. The sprocket teeth are uniquely designed to provide maximum contact surface with the chain henceforth giving lowest applied force per tooth. This ensures longer wear life for the sprocket. In addition the sprockets are designed in such a way that chain elongation tolerances can be absorbed. This will assure a life-long positive engagement between chain and sprocket.
5. Bolts used to assemble the sprockets are paired with nickel or zinc plated steel nuts to ensure easy removal.

Kettenräder

Das Kettenrad ist eines der wichtigsten Komponenten in Transportanlagen. Ein intelligentes Design gewährleistet einen ruhigen Lauf und Effizienz für einen langen Zeitraum. Wir bieten ein umfangreiches Programm in gefräster oder gespritzter Ausführung um Ihren Anforderungen gerecht zu werden.

Movex Kettenräder basieren auf jahrelangen Erfahrungen aus verschiedenen Industrien und vereinigen diese Erkenntnisse in einem innovativen Design.

1. Alle unsere Kettenräder sind zweigeteilt, d.h. einfache Montage und Demontage ohne großen Zeitaufwand.
2. Alle Oberflächen sind glatt um Schmutzablagerungen zu vermeiden dies erleichtert eine schnelle und einfache Reinigung.
3. Die Auswahl der Materialien bietet eine lange Lebensdauer.
4. Die Zahnform ist so gewählt, dass maximale Kontaktfläche mit der Kette / Mattenkette erreicht wird. Dies ermöglicht eine lange Lebensdauer des Kettenrades und der Kette. Das Kettenraddesign ermöglicht die Kompensation einer gewissen Kettenlängung.
5. Schrauben aus Edelstahl verbunden mit einer selbstsichernden Mutter aus vernickeltem Stahl. Damit lassen sich die Räder auch noch nach Jahren problemlos demontieren.



Chain sprockets

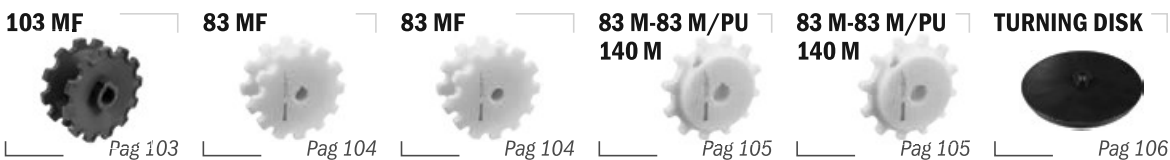
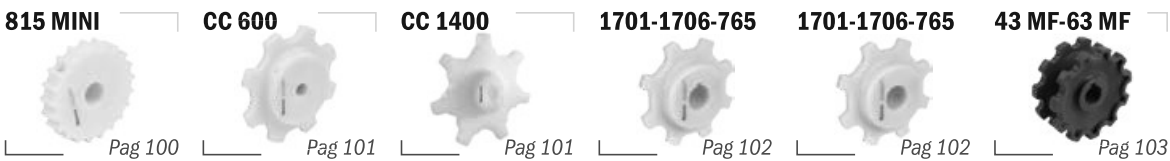
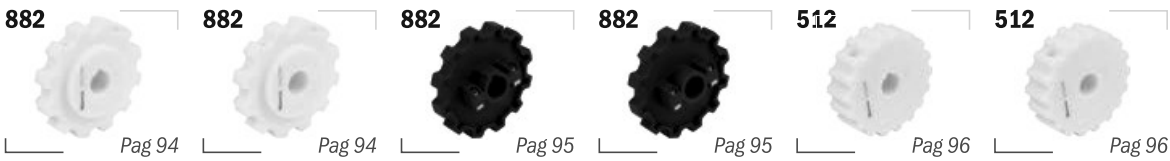
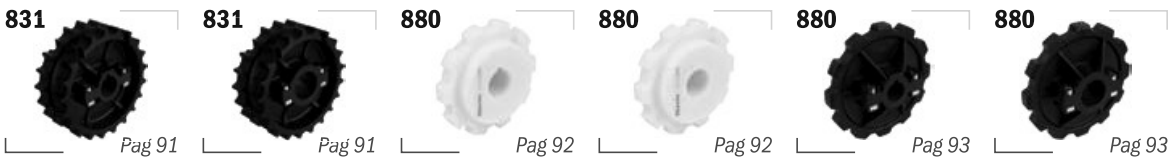
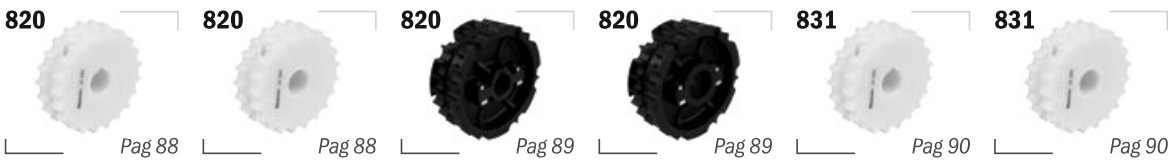
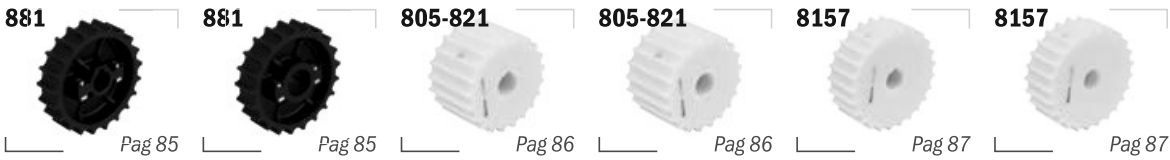
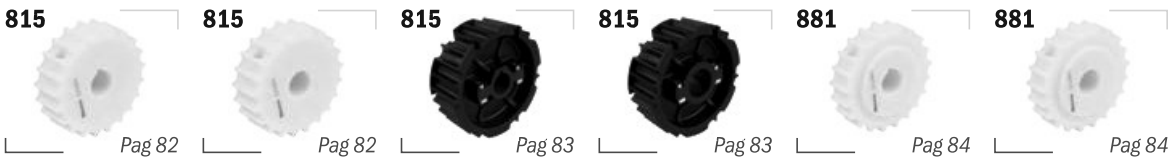

Info
Material:



815

Ruota traino divisa, fresata

Split drive sprocket, machined / geteiltes Antriebskettenrad gefräst

Used also for Series 881 M

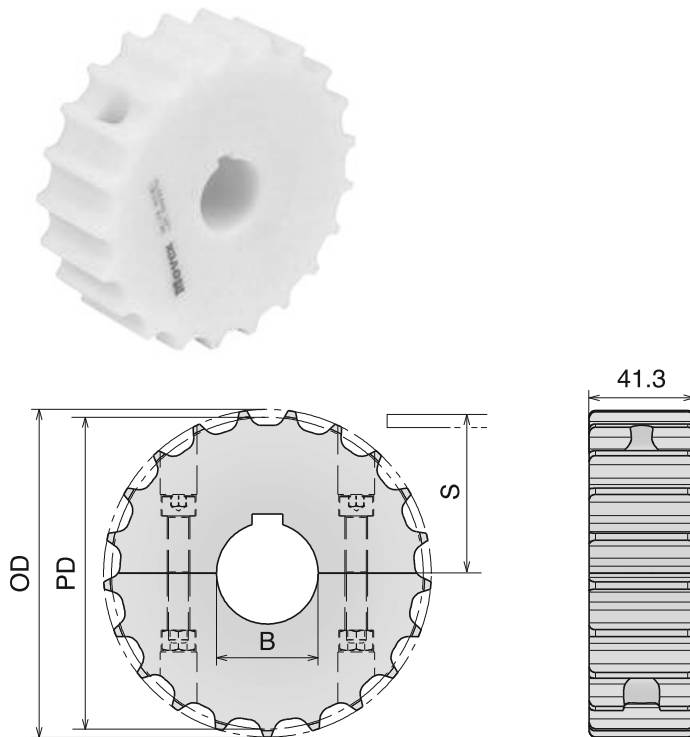

Part	Article-Nr.	Z-	Bore	PD	OD	S
501	50101	17	25	105,5	103,9	55,9
501	50102		30			
501	50103		35			
501	50104		40			
502	50201	19	25	117,3	117,0	61,9
502	50202		30			
502	50203		35			
502	50204		40			
503	50301	21	25	129,3	129,0	67,8
503	50302		30			
503	50303		35			
503	50304		40			
504	50401	23	25	141,2	142,0	73,8
504	50402		30			
504	50403		35			
504	50404		40			
505	50501	25	25	153,2	154,0	79,8
505	50502		30			
505	50503		35			
505	50504		40			
506	50601	27	25	165,2	166,8	85,8
506	50602		30			
506	50603		35			
506	50604		40			
507	50701	29	25	177,2	178,5	91,8
507	50702		30			
507	50703		35			
507	50704		40			

Ruota rinvio divisa, fresata

Split idler sprocket, machined / geteiltes Umlenrad, gefräst

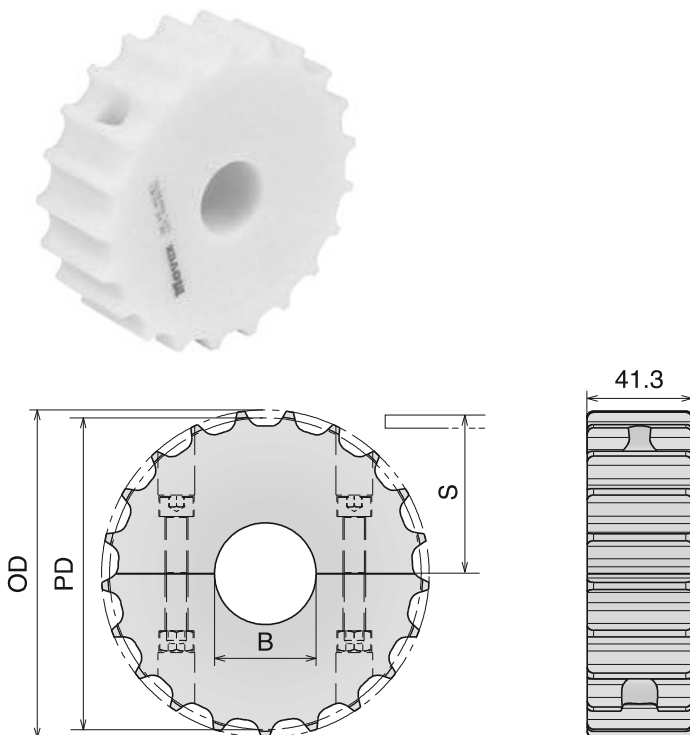

Part	Article-Nr.	Z-	Bore	PD	OD	S
501	50150	17	18*	105,5	103,9	55,9
501	50151		25			
501	50152		30			
501	50153		35			
501	50154		40			
502	50250	19	18*	117,3	117,0	61,9
502	50251		25			
502	50252		30			
502	50253		35			
502	50254		40			
503	50350	21	18*	129,3	129,0	67,8
503	50351		25			
503	50352		30			
503	50353		35			
503	50354		40			
504	50450	23	18*	141,2	142,0	73,8
504	50451		25			
504	50452		30			
504	50453		35			
504	50454		40			
505	50550	25	18*	153,2	154,0	79,8
505	50551		25			
505	50552		30			
505	50553		35			
505	50554		40			
506	50650	27	18*	165,2	166,8	85,8
506	50651		25			
506	50652		30			
506	50653		35			
506	50654		40			
507	50750	29	18*	177,2	178,5	91,8
507	50751		25			
507	50752		30			
507	50753		35			
507	50754		40			

*Plain Bore

Materiale / Material / Materialien:

Poliamide rinforzato/Polyamide reinforced/Verstärktes Polyamid
 Viti: Acciaio inox/Screws: Stainless steel/Schrauben: Edelstahl
 Dadi: Ottone nichelato/Nuts: Nickel plated brass/Mutter: Messing

Ruote dentate per catene / Chain sprockets / Kettenräder für Scharnierbandketten

815 Ruota traino divisa, stampata
Split drive sprocket, molded / geteiltes Antriebskettenrad, gespritzt

Used also for Series 881 M

Part	Article-Nr.	Z-	Bore	PD	OD	S
508	50801	21	25	129,3	129,0	67,8
508	50802		30			
508	50803		35			
508	50804		40			
509	50901	23	25	141,2	142,0	73,8
509	50902		30			
509	50903		35			
509	50904		40			
510	51001	25	25	153,2	154,0	79,8
510	51002		30			
510	51003		35			
510	51004		40			

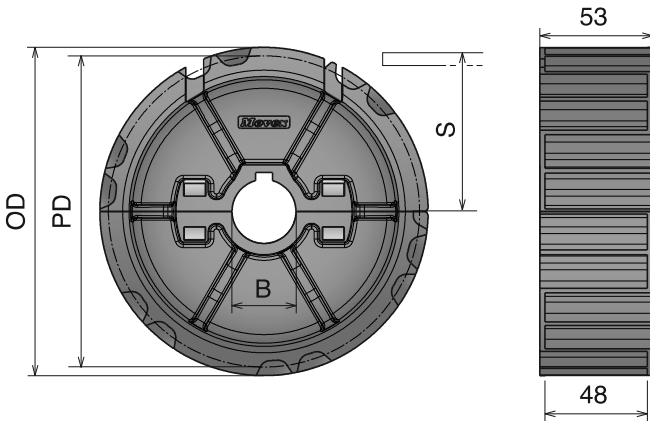

Improved Design and Performance

Ruota rinvio divisa, stampata
Split idler sprocket, molded / geteiltes Umlenkrad, gespritzt

Part	Article-Nr.	Z-	Bore	PD	OD	S
508	50851	21	25	129,3	129,0	67,8
508	50852		30			
508	50853		35			
508	50854		40			
509	50951	23	25	141,2	142,0	73,8
509	50952		30			
509	50953		35			
509	50954		40			
510	51051	25	25	153,2	154,0	79,8
510	51052		30			
510	51053		35			
510	51054		40			

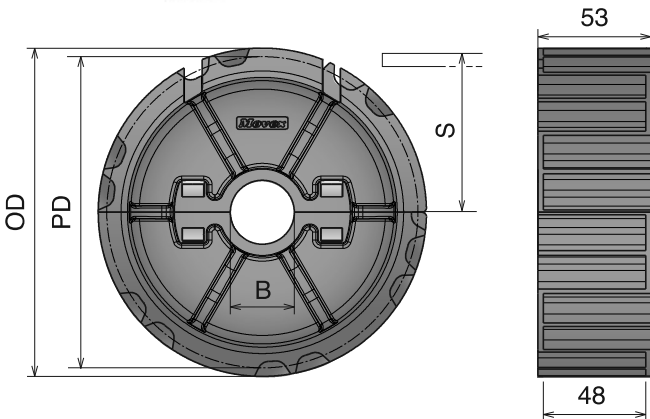

Improved Design and Performance

881 Ruota traino divisa, fresata Split drive sprocket, machined / geteiltes Antriebskettenrad gefräst

Used for Series 881 B and 881 TAB

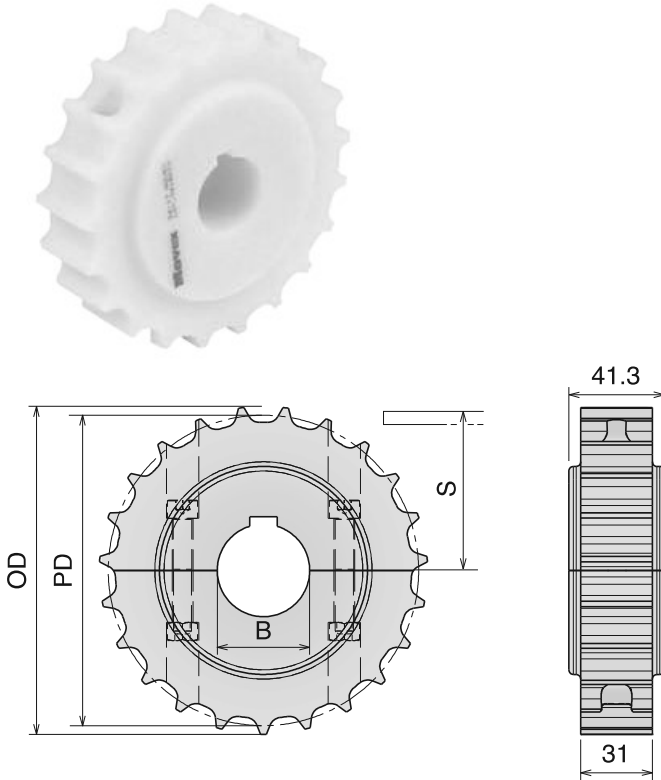

Part	Article-Nr.	Z-	Bore	PD	OD	S
511	51101	17	25	105,5	103,9	55,9
511	51102		30			
511	51103		35			
511	51104		40			
512	51201	19	25	117,3	117,0	61,9
512	51202		30			
512	51203		35			
512	51204		40			
513	51301	21	25	129,3	129,0	67,8
513	51302		30			
513	51303		35			
513	51304		40			
514	51401	23	25	141,2	142,0	73,8
514	51402		30			
514	51403		35			
514	51404		40			
515	51501	25	25	153,2	154,0	79,8
515	51502		30			
515	51503		35			
515	51504		40			
516	51601	27	25	165,2	166,8	85,8
516	51602		30			
516	51603		35			
516	51604		40			
517	51701	29	25	177,2	178,5	91,8
517	51702		30			
517	51703		35			
517	51704		40			

Ruota rinvio divisa, fresata Split idler sprocket, machined / geteiltes Umlenrad, gefräst

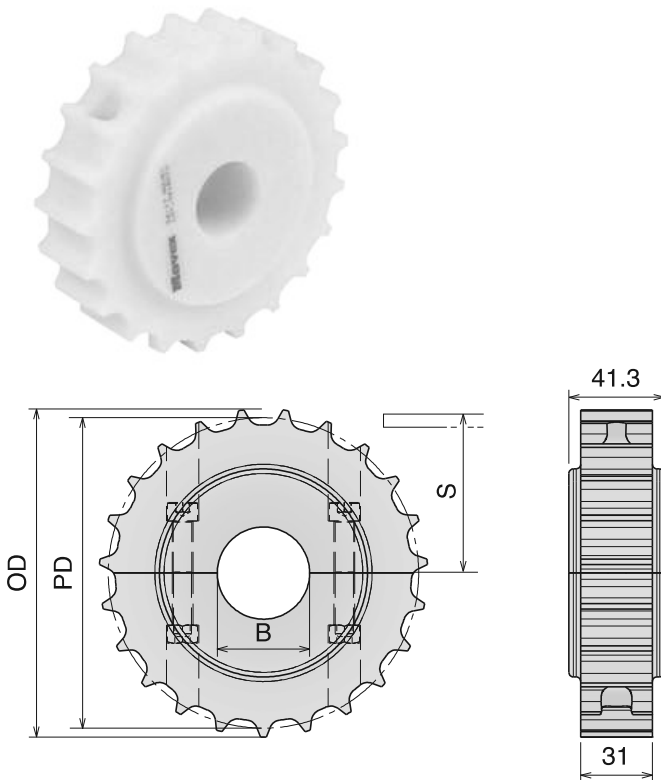

Part	Article-Nr.	Z-	Bore	PD	OD	S
511	51150	17	18*	105,5	103,9	55,9
511	51151		25			
511	51152		30			
511	51153		35			
511	51154		40			
512	51250	19	18*	117,3	117,0	61,9
512	51251		25			
512	51252		30			
512	51253		35			
512	51254		40			
513	51350	21	18*	129,3	129,0	67,8
513	51351		25			
513	51352		30			
513	51353		35			
513	51354		40			
514	51450	23	18*	141,2	142,0	73,8
514	51451		25			
514	51452		30			
514	51453		35			
514	51454		40			
515	51550	25	18*	153,2	154,0	79,8
515	51551		25			
515	51552		30			
515	51553		35			
515	51554		40			
516	51650	27	18*	165,2	166,8	85,8
516	51651		25			
516	51652		30			
516	51653		35			
516	51654		40			
517	51750	29	18*	177,2	178,5	91,8
517	51751		25			
517	51752		30			
517	51753		35			
517	51754		40			

*Plain Bore

Materiale / Material / Materialien:

Poliammide rinforzato / Polyamide reinforced / Verstärktes Polyamid

Viti: Acciaio inox / Screws: Stainless steel / Schrauben: Edelstahl

Dadi: Ottone nichelato / Nuts: Nickel plated brass / Mutter: Messing

Ruote dentate per catene / Chain sprockets / Kettenräder für Scharnierbandketten

881

Ruota traino divisa, stampata Split drive sprocket, molded / geteiltes Antriebskettenrad, gespritzt

Used for Series 881 B and 881 TAB

Part	Article-Nr.	Z-	Bore	PD	OD	S
518	51801	21	25	129,3	129,0	67,8
518	51802		30			
518	51803		35			
518	51804		40			
519	51901	23	25	141,2	142,0	73,8
519	51902		30			
519	51903		35			
519	51904		40			
520	52001	25	25	153,2	154,0	79,8
520	52002		30			
520	52003		35			
520	52004		40			

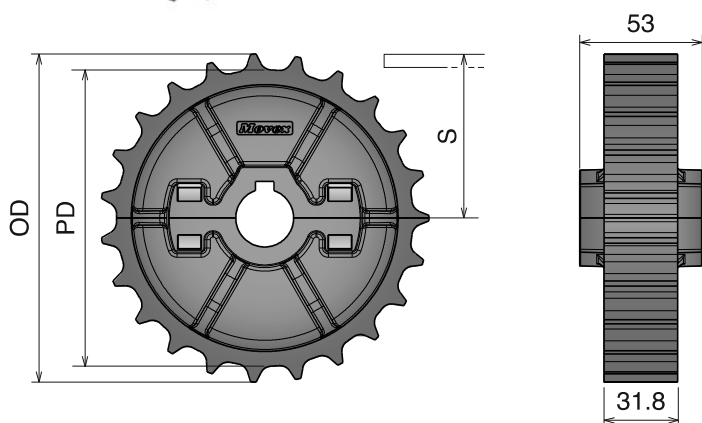

**Improved Design
and Performance**

Ruota rinvio divisa, stampata Split idler sprocket, molded / geteiltes Umlenkrad, gespritzt

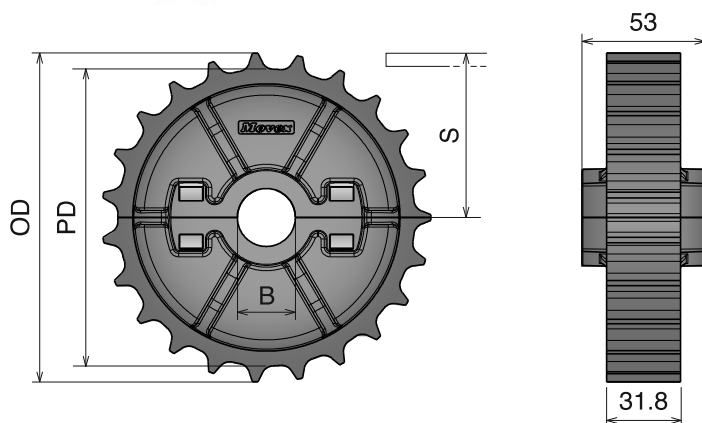

Part	Article-Nr.	Z-	Bore	PD	OD	S
518	51851	21	25	129,3	129,0	67,8
518	51852		30			
518	51853		35			
518	51854		40			
519	51951	23	25	141,2	142,0	73,8
519	51952		30			
519	51953		35			
519	51954		40			
520	52051	25	25	153,2	154,0	79,8
520	52052		30			
520	52053		35			
520	52054		40			

**Improved Design
and Performance**

805-821

Ruota traino divisa, fresata

Split drive sprocket, machined / geteiltes Antriebskettenrad gefräst

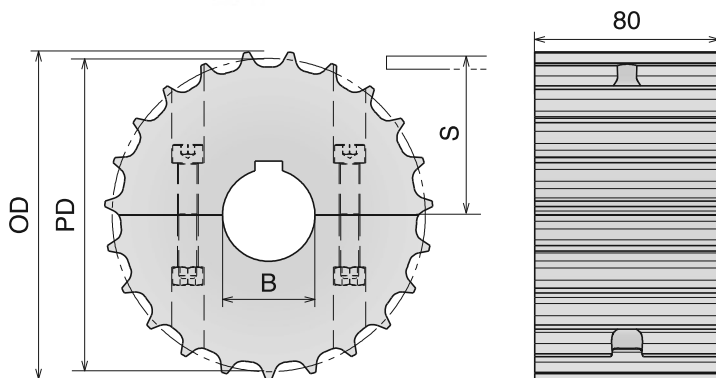

Part	Article-Nr.	Z	Bore	PD	OD	S
521	52101	17	25	105,5	103,9	55,9
521	52102		30			
521	52103		35			
521	52104		40			
522	52201	19	25	117,3	117,0	61,9
522	52202		30			
522	52203		35			
522	52204		40			
523	52301	21	25	129,3	129,0	67,8
523	52302		30			
523	52303		35			
523	52304		40			
524	52401	23	25	141,2	142,0	73,8
524	52402		30			
524	52403		35			
524	52404		40			
525	52501	25	25	153,2	154,0	79,8
525	52502		30			
525	52503		35			
525	52504		40			
526	52601	27	25	165,2	166,8	85,8
526	52602		30			
526	52603		35			
526	52604		40			
527	52701	29	25	177,2	178,5	91,8
527	52702		30			
527	52703		35			
527	52704		40			

Ruota rinvio divisa, fresata

Split idler sprocket, machined / geteiltes Umlenrad, gefräst

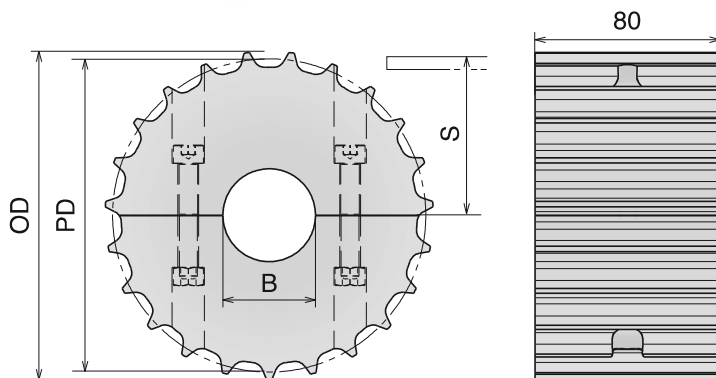

Part	Article-Nr.	Z	Bore	PD	OD	S
521	52150	17	18*	105,5	103,9	55,9
521	52151		25			
521	52152		30			
521	52153		35			
521	52154		40			
522	52250	19	18*	117,3	117,0	61,9
522	52251		25			
522	52252		30			
522	52253		35			
522	52254		40			
523	52350	21	18*	129,3	129,0	67,8
523	52351		25			
523	52352		30			
523	52353		35			
523	52354		40			
524	52450	23	18*	141,2	142,0	73,8
524	52451		25			
524	52452		30			
524	52453		35			
524	52454		40			
525	52550	25	18*	153,2	154,0	79,8
525	52551		25			
525	52552		30			
525	52553		35			
525	52554		40			
526	52650	27	18*	165,2	166,8	85,8
526	52651		25			
526	52652		30			
526	52653		35			
526	52654		40			
527	52750	29	18*	177,2	178,5	91,8
527	52751		25			
527	52752		30			
527	52753		35			
527	52754		40			

*Plain Bore

8157

Ruota traino divisa, fresata

Split drive sprocket, machined / geteiltes Antriebskettenrad gefräst

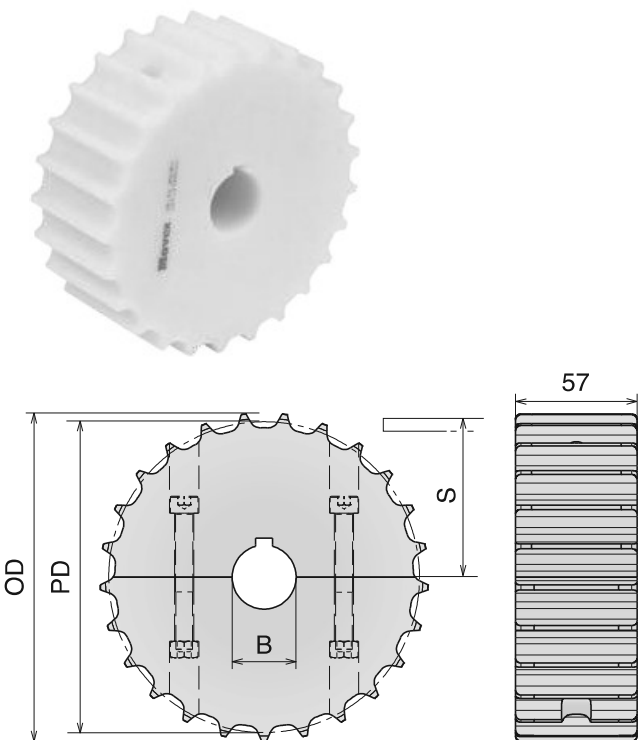

Part	Article-Nr.	Z-	Bore	PD	OD	S
528	52801	17	25	105,5	103,9	55,9
528	52802		30			
528	52803		35			
528	52804		40			
529	52901	19	25	117,3	117,0	61,9
529	52902		30			
529	52903		35			
529	52904		40			
530	53001	21	25	129,3	129,0	67,8
530	53002		30			
530	53003		35			
530	53004		40			
531	53101	23	25	141,2	142,0	73,8
531	53102		30			
531	53103		35			
531	53104		40			
532	53201	25	25	153,2	154,0	79,8
532	53202		30			
532	53203		35			
532	53204		40			
533	53301	27	25	165,2	166,8	85,8
533	53302		30			
533	53303		35			
533	53304		40			
534	53401	29	25	177,2	178,5	91,8
534	53402		30			
534	53403		35			
534	53404		40			

Ruota rinvio divisa, fresata

Split idler sprocket, machined / geteiltes Umlenrad, gefräst

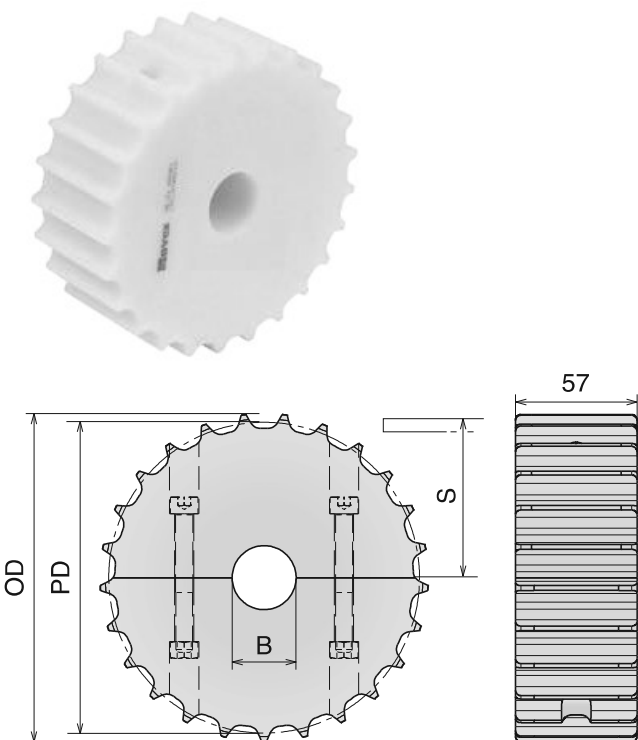

Part	Article-Nr.	Z-	Bore	PD	OD	S
528	52850	17	18*	105,5	103,9	55,9
528	52851		25			
528	52852		30			
528	52853		35			
528	52854		40			
529	52950	19	18*	117,3	117,0	61,9
529	52951		25			
529	52952		30			
529	52953		35			
529	52954		40			
530	53050	21	18*	129,3	129,0	67,8
530	53051		25			
530	53052		30			
530	53053		35			
530	53054		40			
531	53150	23	18*	141,2	142,0	73,8
531	53151		25			
531	53152		30			
531	53153		35			
531	53154		40			
532	53250	25	18*	153,2	154,0	79,8
532	53251		25			
532	53252		30			
532	53253		35			
532	53254		40			
533	53350	27	18*	165,2	166,8	85,8
533	53351		25			
533	53352		30			
533	53353		35			
533	53354		40			
534	53450	29	18*	177,2	178,5	91,8
534	53451		25			
534	53452		30			
534	53453		35			
534	53454		40			

*Plain Bore

820

Ruota traino divisa, fresata

Split drive sprocket, machined / geteiltes Antriebskettenrad gefräst

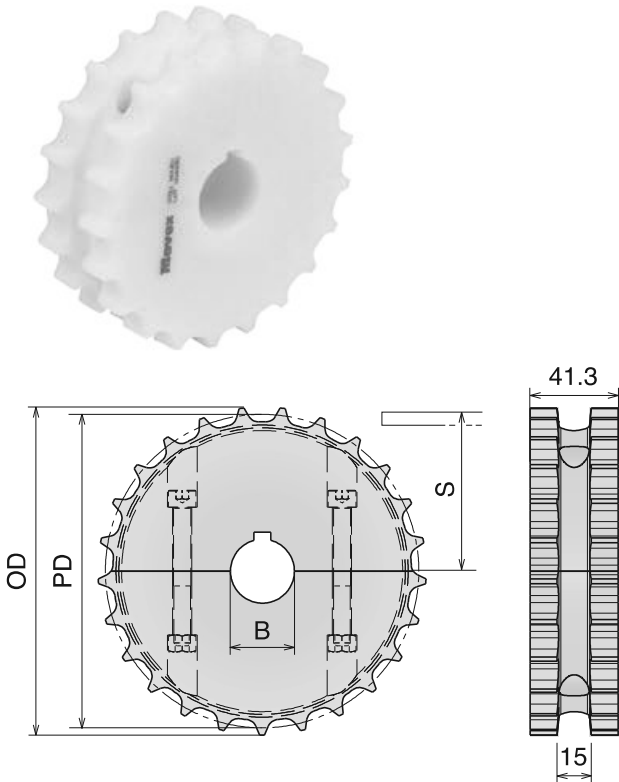

Part	Article-Nr.	Z-	Bore	PD	OD	S
535	53501	17	25	105,5	103,9	55,9
535	53502		30			
535	53503		35			
535	53504		40			
536	53601	19	25	117,3	117,0	61,9
536	53602		30			
536	53603		35			
536	53604		40			
537	53701	21	25	129,3	129,0	67,8
537	53702		30			
537	53703		35			
537	53704		40			
538	53801	23	25	141,2	142,0	73,8
538	53802		30			
538	53803		35			
538	53804		40			
539	53901	25	25	153,2	154,0	79,8
539	53902		30			
539	53903		35			
539	53904		40			
540	54001	27	25	165,2	166,8	85,8
540	54002		30			
540	54003		35			
540	54004		40			
541	54101	29	25	177,2	178,5	91,8
541	54102		30			
541	54103		35			
541	54104		40			

Ruota rinvio divisa, fresata

Split idler sprocket, machined / geteiltes Umlenrad, gefräst

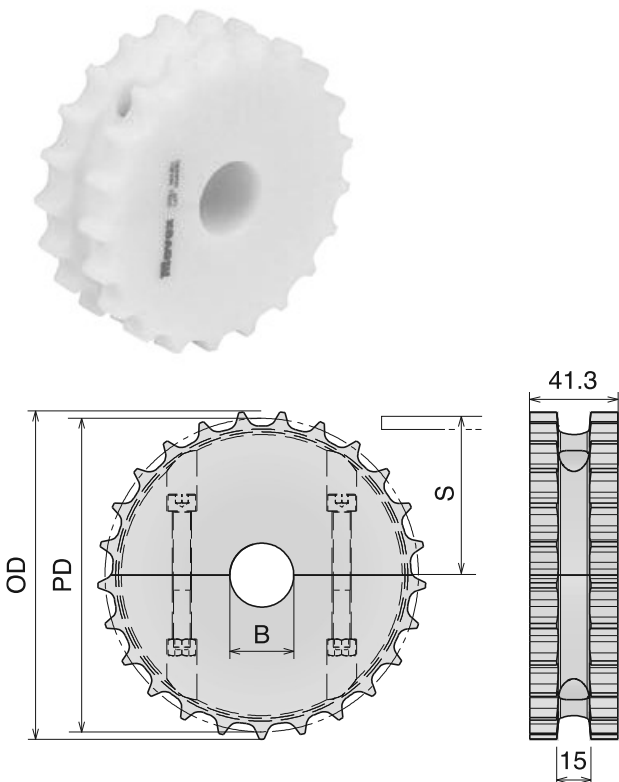

Part	Article-Nr.	Z-	Bore	PD	OD	S
535	53550	17	18*	105,5	103,9	55,9
535	53551		25			
535	53552		30			
535	53553		35			
535	53554		40			
536	53650	19	18*	117,3	117,0	61,9
536	53651		25			
536	53652		30			
536	53653		35			
536	53654		40			
537	53750	21	18*	129,3	129,0	67,8
537	53751		25			
537	53752		30			
537	53753		35			
537	53754		40			
538	53850	23	18*	141,2	142,0	73,8
538	53851		25			
538	53852		30			
538	53853		35			
538	53854		40			
539	53950	25	18*	153,2	154,0	79,8
539	53951		25			
539	53952		30			
539	53953		35			
539	53954		40			
540	54050	27	18*	165,2	166,8	85,8
540	54051		25			
540	54052		30			
540	54053		35			
540	54054		40			
541	54150	29	18*	177,2	178,5	91,8
541	54151		25			
541	54152		30			
541	54153		35			
541	54154		40			

*Plain Bore

Materiale / Material / Materialien:

Poliamide rinforzato / Polyamide reinforced / Verstärktes Polyamid
 Viti: Acciaio inox / Screws: Stainless steel / Schrauben: Edelstahl
 Dadi: Ottone nichelato / Nuts: Nickel plated brass / Mutter: Messing

820

Ruota traino divisa, stampata
Split drive sprocket, molded / geteiltes Antriebskettenrad, gespritzt

Part	Article-Nr.	Z-	Bore	PD	OD	S
542	54201	21	25	129,3	129,0	67,8
542	54202		30			
542	54203		35			
542	54204		40			
543	54301	23	25	141,2	142,0	73,8
543	54302		30			
543	54303		35			
543	54304		40			
544	54401	25	25	153,2	154,0	79,8
544	54402		30			
544	54403		35			
544	54404		40			

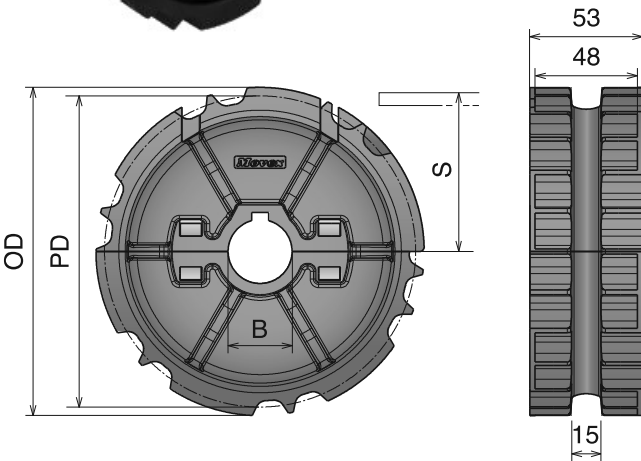

Improved Design and Performance

Ruota rinvio divisa, stampata
Split idler sprocket, molded / geteiltes Umlenkrad, gespritzt

Part	Article-Nr.	Z-	Bore	PD	OD	S
542	54251	21	25	129,3	129,0	67,8
542	54252		30			
542	54253		35			
542	54254		40			
543	54351	23	25	141,2	142,0	73,8
543	54352		30			
543	54353		35			
543	54354		40			
544	54451	25	25	153,2	154,0	79,8
544	54452		30			
544	54453		35			
544	54454		40			

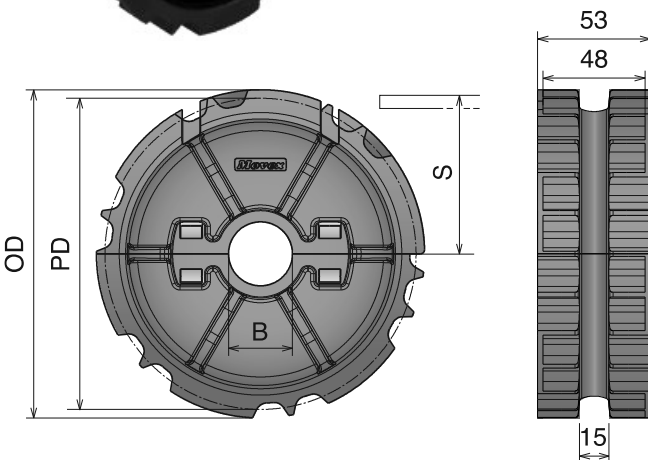

Improved Design and Performance

831

Ruota traino divisa, fresata

Split drive sprocket, machined / geteiltes Antriebskettenrad gefräst

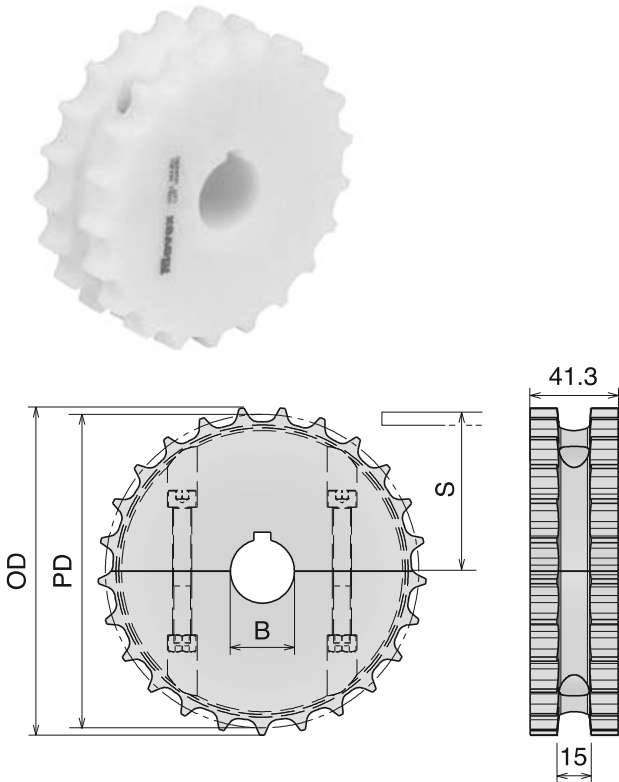

Part	Article-Nr.	Z-	Bore	PD	OD	S
535	53501	17	25	105,5	103,9	55,1
535	53502		30			
535	53503		35			
535	53504		40			
536	53601	19	25	117,3	117,0	61,1
536	53602		30			
536	53603		35			
536	53604		40			
537	53701	21	25	129,3	129,0	67,0
537	53702		30			
537	53703		35			
537	53704		40			
538	53801	23	25	141,2	142,0	73,0
538	53802		30			
538	53803		35			
538	53804		40			
539	53901	25	25	153,2	154,0	79,8
539	53902		30			
539	53903		35			
539	53904		40			
540	54001	27	25	165,2	166,8	85,0
540	54002		30			
540	54003		35			
540	54004		40			
541	54101	29	25	177,2	178,5	91,0
541	54102		30			
541	54103		35			
541	54104		40			

Ruota rinvio divisa, fresata

Split idler sprocket, machined / geteiltes Umlenrad, gefräst

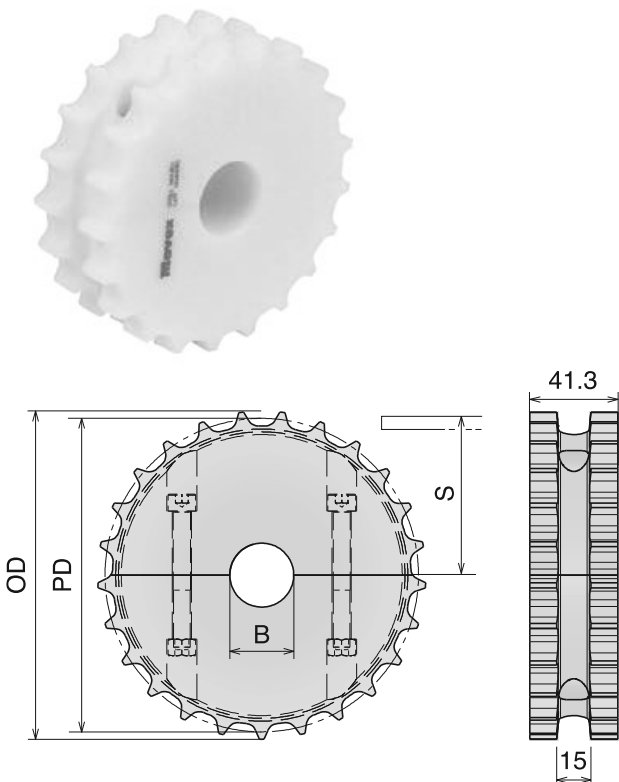

Part	Article-Nr.	Z-	Bore	PD	OD	S
535	53550	17	18*	105,5	103,9	55,1
535	53551		25			
535	53552		30			
535	53553		35			
535	53554		40			
536	53650	19	18*	117,3	117,0	61,1
536	53651		25			
536	53652		30			
536	53653		35			
536	53654		40			
537	53750	21	18*	129,3	129,0	67,0
537	53751		25			
537	53752		30			
537	53753		35			
537	53754		40			
538	53850	23	18*	141,2	142,0	73,0
538	53851		25			
538	53852		30			
538	53853		35			
538	53854		40			
539	53950	25	18*	153,2	154,0	79,0
539	53951		25			
539	53952		30			
539	53953		35			
539	53954		40			
540	54050	27	18*	165,2	166,8	85,0
540	54051		25			
540	54052		30			
540	54053		35			
540	54054		40			
541	54150	29	18*	177,2	178,5	91,0
541	54151		25			
541	54152		30			
541	54153		35			
541	54154		40			

*Plain Bore

Materiale / Material / Materialien:

Poliammide rinforzato/Polyamide reinforced/Verstärktes Polyamid
 Viti: Acciaio inox/Screws: Stainless steel/Schrauben: Edelstahl
 Dadi: Ottone nichelato/Nuts: Nickel plated brass/Mutter: Messing

Ruote dentate per catene / Chain sprockets / Kettenräder für Scharnierbandketten

831

Ruota traino divisa, stampata Split drive sprocket, molded / geteiltes Antriebskettenrad, gespritzt

New

Part	Article-Nr.	Z-	Bore	PD	OD	S
542	54201-2L	21	25	129,3	129,0	67,0
542	54202-2L		30			
542	54203-2L		35			
542	54204-2L		40			
543	54301-2L	23	25	141,2	142,0	73,0
543	54302-2L		30			
543	54303-2L		35			
543	54304-2L		40			
544	54401-2L	25	25	153,2	154,0	79,0
544	54402-2L		30			
544	54403-2L		35			
544	54404-2L		40			

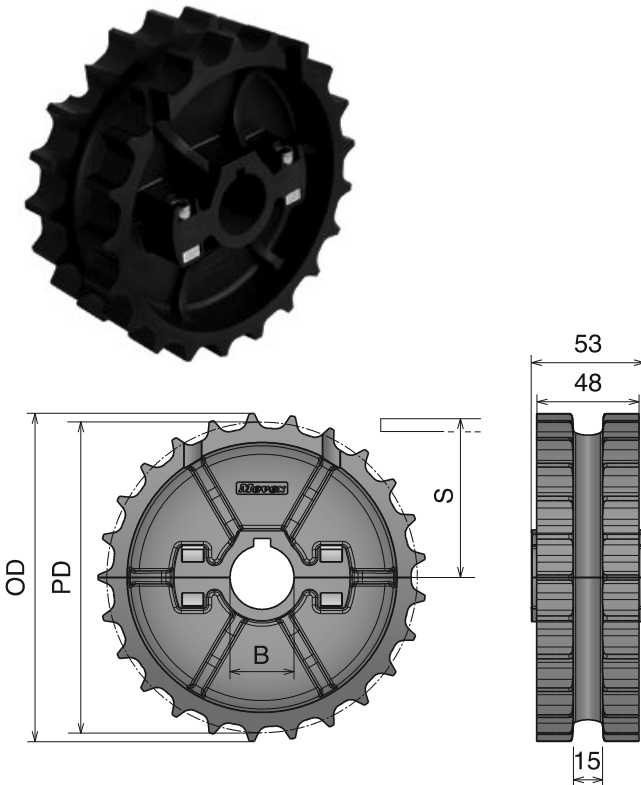
**Improved Design
and Performance**

Ruota rinvio divisa, stampata Split idler sprocket, molded / geteiltes Umlenkrad, gespritzt

Part	Article-Nr.	Z-	Bore	PD	OD	S
542	54251-2L	21	25	129,3	129,0	67,0
542	54252-2L		30			
542	54253-2L		35			
542	54254-2L		40			
543	54351-2L	23	25	141,2	142,0	73,0
543	54352-2L		30			
543	54353-2L		35			
543	54354-2L		40			
544	54451-2L	25	25	153,2	154,0	79,0
544	54452-2L		30			
544	54453-2L		35			
544	54454-2L		40			

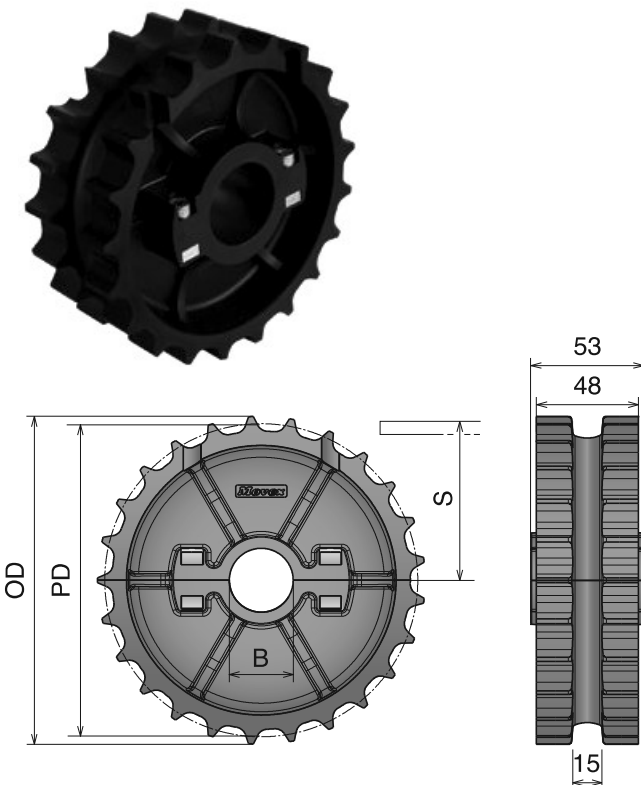
**Improved Design
and Performance**

880

Ruota traino divisa, fresata

Split drive sprocket, machined / geteiltes Antriebskettenrad gefräst

Also suitable for Series 828 - 878 TAB - 879 M - 879 TAB - 888 - 888 GT

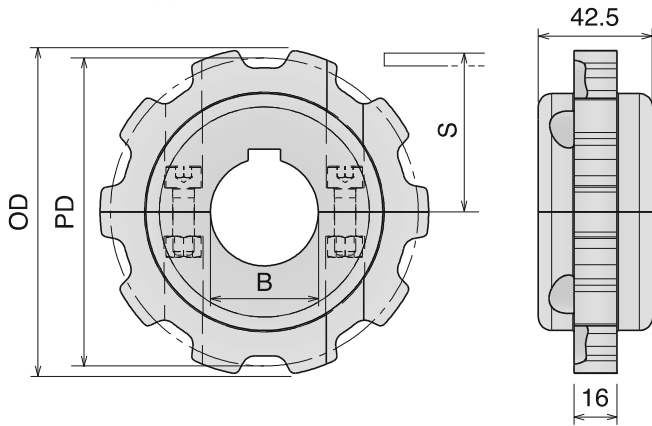

Part	Article-Nr.	Z	Bore	PD	OD	S
545	54501	9	25	111,4	110,0	59,3
545	54502		30			
545	54503		35			
545	54504		40			
546	54601	10	25	123,3	122,0	65,25
546	54602		30			
546	54603		35			
546	54604		40			
547	54701	11	25	135,2	135,0	71,2
547	54702		30			
547	54703		35			
547	54704		40			
548	54801	12	25	147,2	147,3	77,2
548	54802		30			
548	54803		35			
548	54804		40			

Ruota rinvio divisa, fresata

Split idler sprocket, machined / geteiltes Umlenrad, gefräst

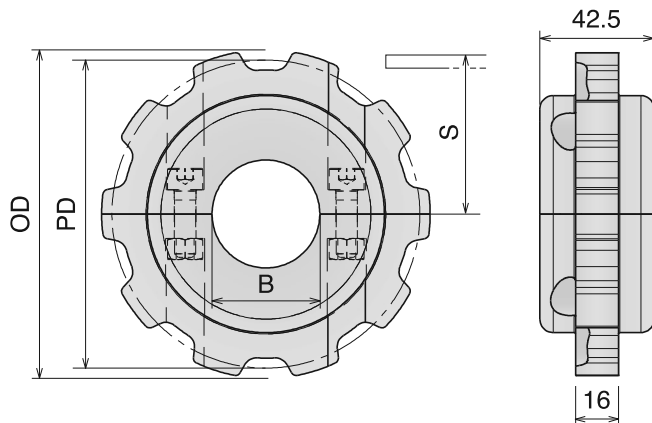

Part	Article-Nr.	Z	Bore	PD	OD	S
545	54550	9	18*	111,4	110,0	59,3
545	54551		25			
545	54552		30			
545	54553		35			
545	54554		40			
546	54650	10	18*	123,3	122,0	65,25
546	54651		25			
546	54652		30			
546	54653		35			
546	54654		40			
547	54750	11	18*	135,2	135,0	71,2
547	54751		25			
547	54752		30			
547	54753		35			
547	54754		40			
548	54850	12	18*	147,2	147,3	77,2
548	54851		25			
548	54852		30			
548	54853		35			
548	54854		40			

*Plain Bore

Materiale / Material / Materialien:

Poliamide rinforzato/Polyamide reinforced/Verstärktes Polyamid
 Viti: Acciaio inox/Screws: Stainless steel/Schrauben: Edelstahl
 Dadi: Ottone nichelato/Nuts: Nickel plated brass/Mutter: Messing

Ruote dentate per catene / Chain sprockets / Kettenräder für Scharnierbandketten

880

Ruota traino divisa, stampata Split drive sprocket, molded / geteiltes Antriebskettenrad, gespritzt

Also suitable for Series 828 - 878 TAB - 879 M - 879 TAB - 888 - 888 GT

Part	Article-Nr.	Z-	Bore	PD	OD	S
549	54901	10	25	123,3	122,0	65,25
549	54902		30			
549	54903		35			
549	54904		40			
550	55001	12	25	147,2	147,3	77,2
550	55002		30			
550	55003		35			
550	55004		40			

**Improved Design
 and Performance**

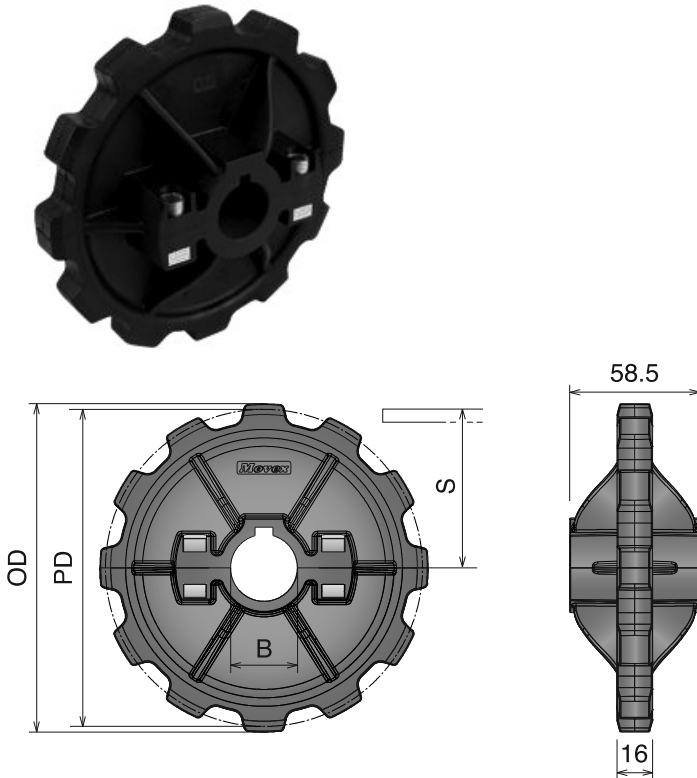

Ruota rinvio divisa, stampata Split idler sprocket, molded / geteiltes Umlenkrad, gespritzt

Part	Article-Nr.	Z-	Bore	PD	OD	S
549	54951	10	25	123,3	122,0	65,25
549	54952		30			
549	54953		35			
549	54954		40			
550	55051	12	25	147,2	147,3	77,2
550	55052		30			
550	55053		35			
550	55054		40			

**Improved Design
 and Performance**

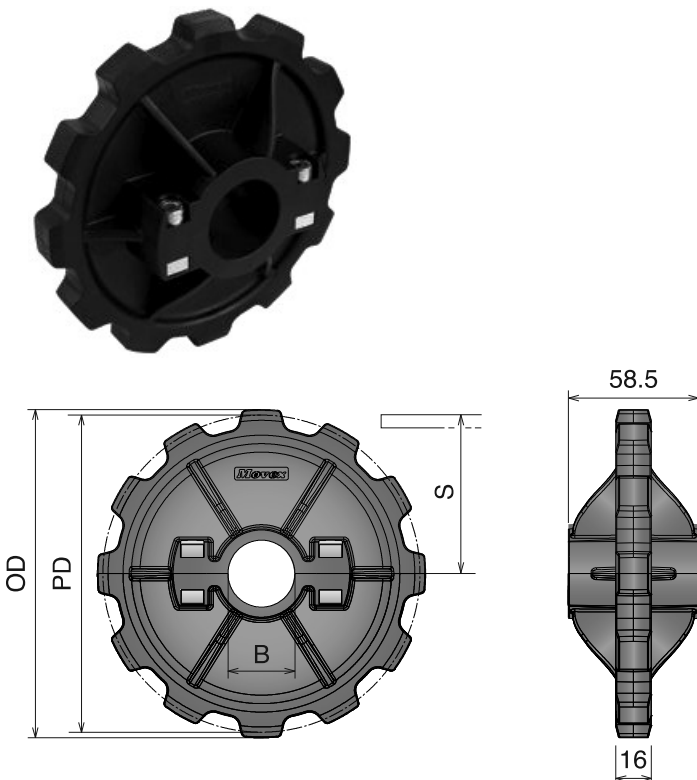

882

Ruota traino divisa, fresata

Split drive sprocket, machined / geteiltes Antriebskettenrad gefräst

Also suitable for Series 8257

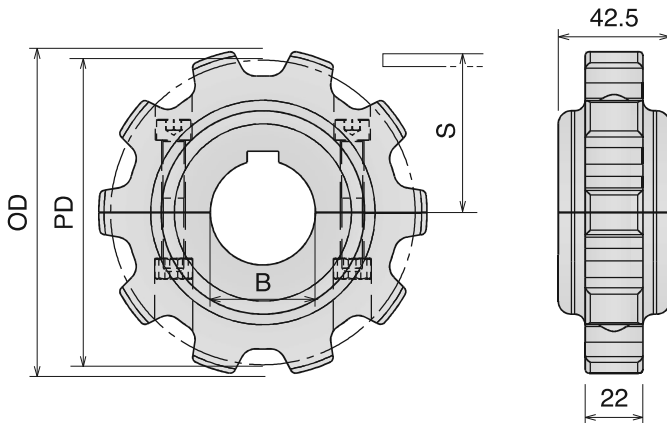

Part	Article-Nr.	Z-	Bore	PD	OD	S
551	55101	9	25	111,4	112,0	60,5
551	55102		30			
551	55103		35			
551	55104		40			
552	55201	10	25	123,2	125,0	66,4
552	55202		30			
552	55203		35			
552	55204		40			
553	55301	11	25	135,2	137,0	72,4
553	55302		30			
553	55303		35			
553	55304		40			
554	55401	12	25	147,2	149,0	78,4
554	55402		30			
554	55403		35			
554	55404		40			

Ruota rinvio divisa, fresata

Split idler sprocket, machined / geteiltes Umlenrad, gefräst

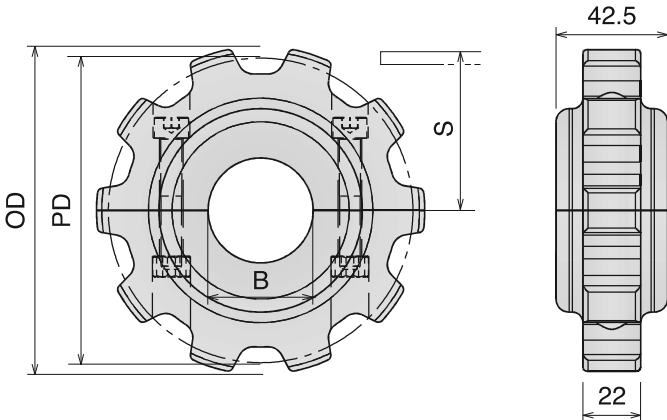

Part	Article-Nr.	Z-	Bore	PD	OD	S
551	55150	9	18*	111,4	112,0	60,5
551	55151		25			
551	55152		30			
551	55153		35			
551	55154		40			
552	55250	10	18*	123,2	125,0	66,4
552	55251		25			
552	55252		30			
552	55253		35			
552	55254		40			
553	55350	11	18*	135,2	137,0	72,4
553	55351		25			
553	55352		30			
553	55353		35			
553	55354		40			
554	55450	12	18*	147,2	149,0	78,4
554	55451		25			
554	55452		30			
554	55453		35			
554	55454		40			

*Plain Bore

Materiale / Material / Materialien:

Poliammide rinforzato / Polyamide reinforced / Verstärktes Polyamid

Viti: Acciaio inox / Screws: Stainless steel / Schrauben: Edelstahl

Dadi: Ottone nichelato / Nuts: Nickel plated brass / Mutter: Messing

882

Ruota traino divisa, stampata

Split drive sprocket, molded / geteiltes Antriebskettenrad, gespritzt

Also suitable for Series 8257

Part	Article-Nr.	Z-	Bore	PD	OD	S
555	55501	10	25	123,2	125,0	66,4
555	55502		30			
555	55503		35			
555	55504		40			
556	55601	12	25	147,2	149,0	78,4
556	55602		30			
556	55603		35			
556	55604		40			

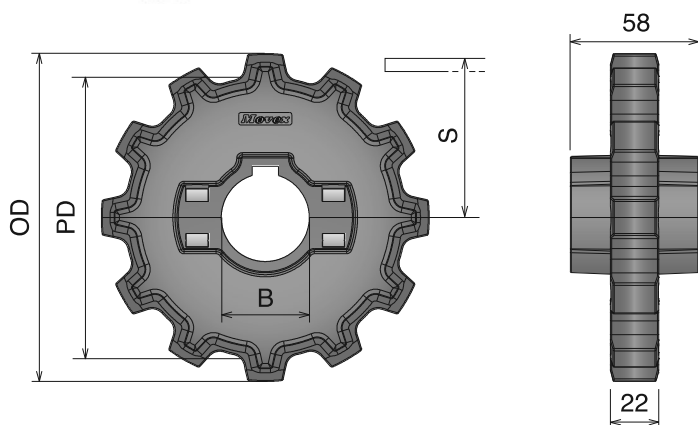

Ruota rinvio divisa, stampata

Split idler sprocket, molded / geteiltes Umlenkrad, gespritzt

Part	Article-Nr.	Z-	Bore	PD	OD	S
555	55551	10	25	123,2	125,0	66,4
555	55552		30			
555	55553		35			
555	55554		40			
556	55651	12	25	147,2	149,0	78,4
556	55652		30			
556	55653		35			
556	55654		40			

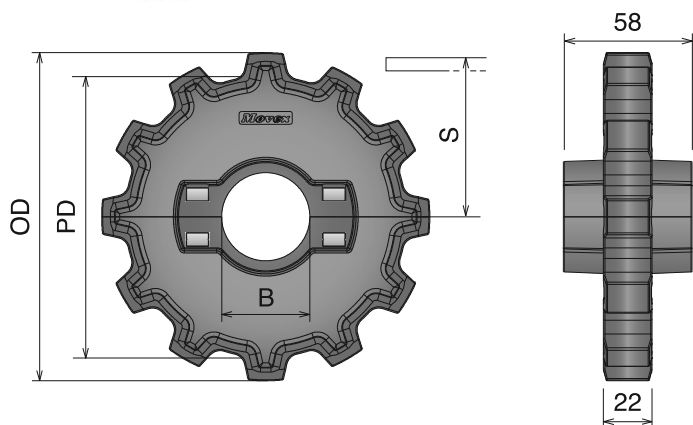

512 Ruota traino divisa, fresata Split drive sprocket, machined / geteiltes Antriebskettenrad gefräst

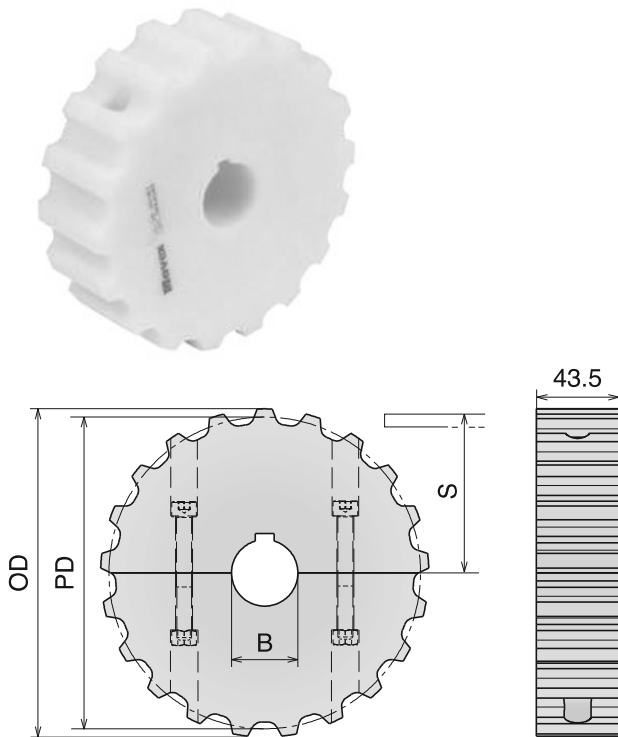

Part	Article-Nr.	Z	Bore	PD	OD	S
557	55701	13	25	108,0	106,1	57,2
557	55702		30			
557	55703		35			
557	55704		40			
558	55801	15	25	124,0	122,2	65,2
558	55802		30			
558	55803		35			
558	55804		40			
559	55901	17	25	138,2	138,2	72,3
559	55902		30			
559	55903		35			
559	55904		40			
560	56001	18	25	146,3	146,4	76,4
560	56002		30			
560	56003		35			
560	56004		40			
561	56101	19	25	154,3	155,7	80,4
561	56102		30			
561	56103		35			
561	56104		40			
562	56201	21	25	170,4	173,0	88,4
562	56202		30			
562	56203		35			
562	56204		40			
563	56301	23	25	186,5	190,0	96,5
563	56302		30			
563	56303		35			
563	56304		40			
564	56401	25	25	202,7	204,0	104,6
564	56402		30			
564	56403		35			
564	56404		40			

Ruota rinvio divisa, fresata Split idler sprocket, machined / geteiltes Umlenrad, gefräst

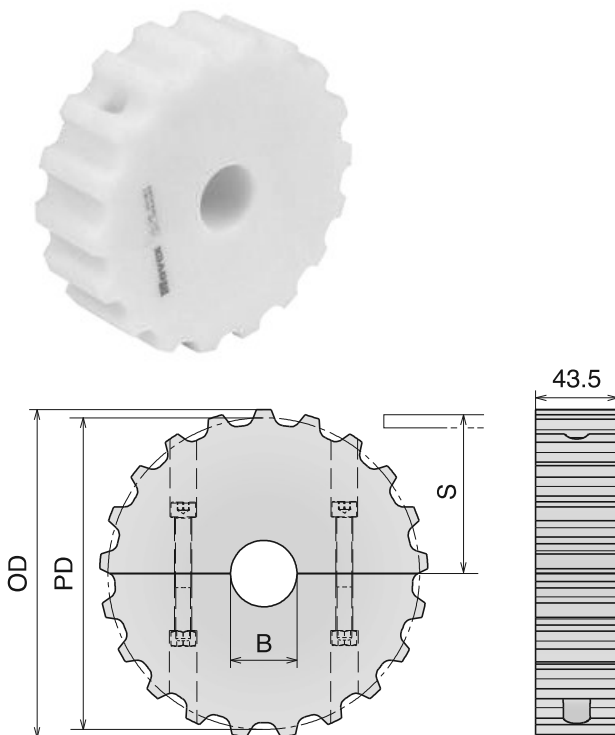

Part	Article-Nr.	Z	Bore	PD	OD	S
557	55750	13	18*	108,0	106,1	57,2
557	55751		25			
557	55752		30			
557	55753		35			
557	55754		40			
558	55850	15	18*	124,0	122,2	65,2
558	55851		25			
558	55852		30			
558	55853		35			
558	55854		40			
559	55950	17	18*	138,2	138,2	72,3
559	55951		25			
559	55952		30			
559	55953		35			
559	55954		40			
560	56050	18	18*	146,3	146,4	76,4
560	56051		25			
560	56052		30			
560	56053		35			
560	56054		40			
561	56150	19	18*	154,3	155,7	80,4
561	56151		25			
561	56152		30			
561	56153		35			
561	56154		40			
562	56250	21	18*	170,4	173,0	88,4
562	56251		25			
562	56252		30			
562	56253		35			
562	56254		40			
563	56350	23	18*	186,5	190,0	96,5
563	56351		25			
563	56352		30			
563	56353		35			
563	56354		40			
564	56450	25	18*	202,7	204,0	104,6
564	56451		25			
564	56452		30			
564	56453		35			
564	56454		40			

*Plain Bore

Materiale / Material / Materialien:

Poliamide/Polyamide/Polyamid

Viti: Acciaio inox/Screws: Stainless steel/Schrauben: Edelstahl

Dadi: ferro zincato/Nuts: zinc plated steel/Mutter: verzinkter Stahl

815-8157

Ruote dentate per catene / Chain sprockets / Kettenräder für Scharnierbandketten

815 Ruota flangiata divisa, fresata
Split sprocket with guides, machined / Geteiltes Kettenrad mit Bordscheibe, gefräst

Anelli Inox / SS Guide-rings / Edelstahl Bordscheibe	Part	Article-Nr.	Z-	Bore	PD	OD	S	Ø screw
	503	50301G	21	25	129,3	129,0	67,8	104,0
	503	50302G		30				
	503	50303G		35				
	503	50304G		40				
	504	50401G	23	25	141,2	142,0	73,8	116,0
	504	50402G		30				
	504	50403G		35				
	504	50404G		40				
	505	50501G	25	25	153,2	154,0	79,8	128,0
	505	50502G		30				
	505	50503G		35				
	505	50504G		40				

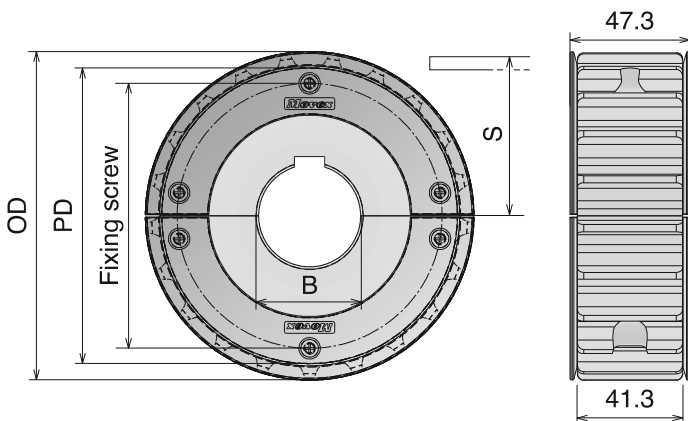

8157 Ruota flangiata divisa, fresata
Split sprocket with guides, machined / Geteiltes Kettenrad mit Bordscheibe, gefräst

Anelli Inox / SS Guide-rings / Edelstahl Bordscheibe	Part	Article-Nr.	Z-	Bore	PD	OD	S	Ø screw
	530	53001G	21	25	129,3	129,0	67,8	104,0
	530	53002G		30				
	530	53003G		35				
	530	53004G		40				
	531	53101G	23	25	141,2	142,0	73,8	116,0
	531	53102G		30				
	531	53103G		35				
	531	53104G		40				
	532	53201G	25	25	153,2	154,0	79,8	128,0
	532	53202G		30				
	532	53203G		35				
	532	53204G		40				

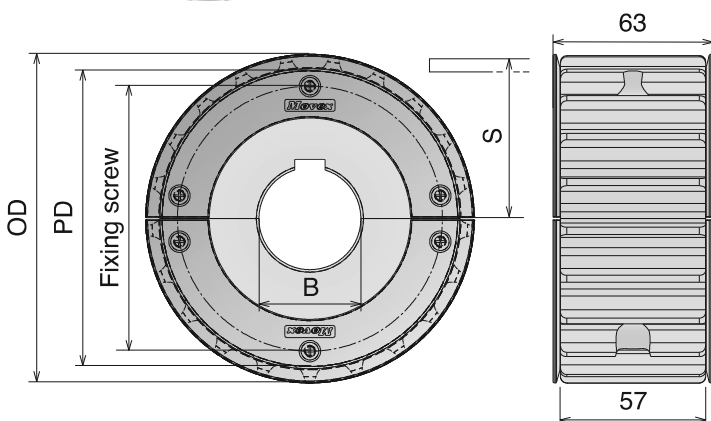

805

Ruota flangiata divisa, fresata

Split sprocket with guides, machined / Geteiltes Kettenrad mit Bordscheibe, gefräst

Anelli Inox / SS Guide-rings / Edelstahl Bordscheibe



Part	Article-Nr.	Z-	Bore	PD	OD	S	Ø screw
523	52301G	21	25	129,3	129,0	67,8	104,0
523	52302G		30				
523	52303G		35				
523	52304G		40				
524	52401G	23	25	141,2	142,0	73,8	116,0
524	52402G		30				
524	52403G		35				
524	52404G		40				
525	52501G	25	25	153,2	154,0	79,8	128,0
525	52502G		30				
525	52503G		35				
525	52504G		40				

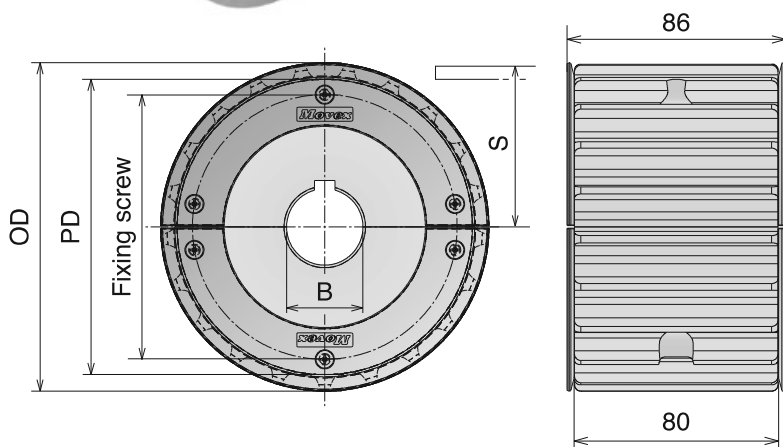

820

Ruota flangiata divisa, fresata

Split sprocket with guides, machined / Geteiltes Kettenrad mit Bordscheibe, gefräst

Anelli Inox / SS Guide-rings / Edelstahl Bordscheibe



Part	Article-Nr.	Z-	Bore	PD	OD	S	Ø screw
537	53701G	21	25	129,3	129,0	67,8	104,0
537	53702G		30				
537	53703G		35				
537	53704G		40				
538	53801G	23	25	141,2	142,0	73,8	116,0
538	53802G		30				
538	53803G		35				
538	53804G		40				
539	53901G	25	25	153,2	154,0	79,8	128,0
539	53902G		30				
539	53903G		35				
539	53904G		40				

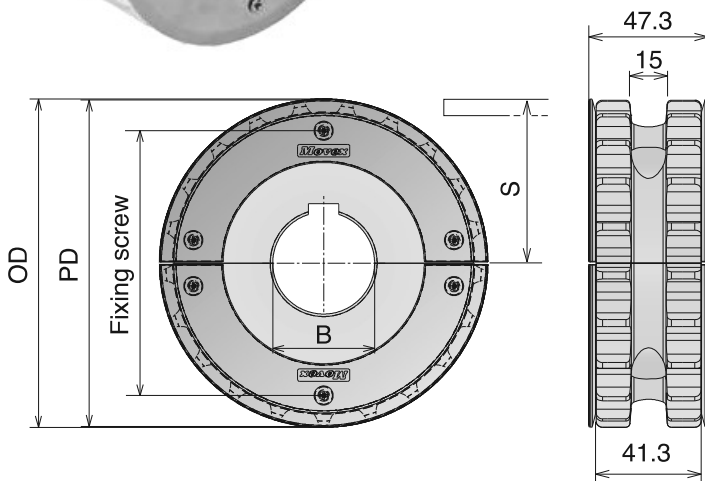

Materiale / Material / Materialien:

Poliamide/Polyamide/Polyamid

Viti: Acciaio inox/Screws: Stainless steel/Schrauben: Edelstahl

Dadi: ferro zincato/Nuts: zinc plated steel/Mutter: verzinkter Stahl

Ruote dentate per catene / Chain sprockets / Kettenräder für Scharnierbandketten

512

Ruota flangiata divisa, fresata

Split sprocket with guides, machined / Geteiltes Kettenrad mit Bordscheibe, gefräst

Anelli Inox / SS Guide-rings / Edelstahl Bordscheibe	Part	Article-Nr.	Z-	Bore	PD	OD	S	Ø screw
	576	57601G	18	25	146,3	147,0	76,4	110,0
	576	57602G		30				
	576	57603G		35				
	576	57604G		40				

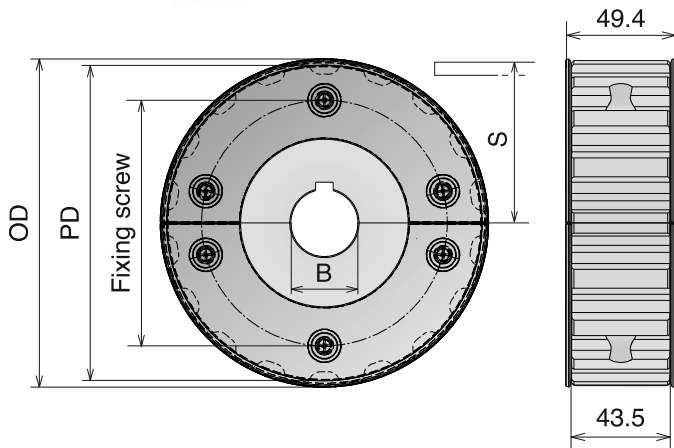

815 MINI

Ruota traino divisa, fresata

Split drive sprocket, machined / geteiltes Antriebskettenrad gefräst

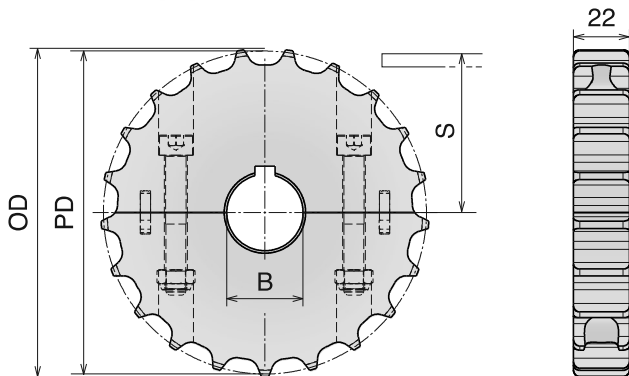

Part	Article-Nr.	Z	Bore	PD	OD	S
580	58001	19	25	117,3	117,0	61,9
580	58002		30			
580	58003		35			
580	58004		40			
581	58101	21	25	129,3	129,0	67,8
581	58102		30			
581	58103		35			
581	58104		40			
582	58201	23	25	141,2	142,0	73,8
582	58202		30			
582	58203		35			
582	58204		40			
583	58301	25	25	153,2	154,0	79,8
583	58302		30			
583	58303		35			
583	58304		40			

Ruota rinvio divisa, fresata

Split idler sprocket, machined / geteiltes Umlenrad, gefräst

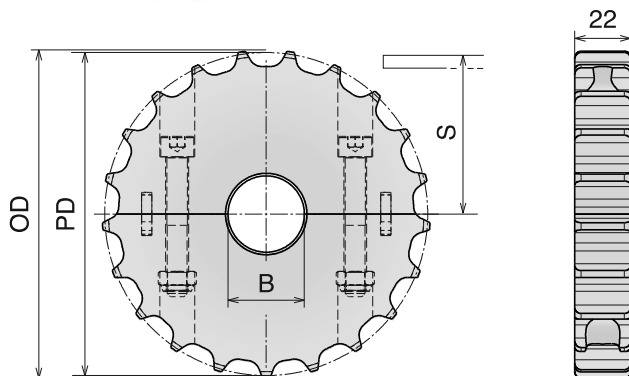

Part	Article-Nr.	Z	Bore	PD	OD	S
580	58050	19	18*	117,3	117,0	61,9
580	58051		25			
580	58052		30			
580	58053		35			
580	58054		40			
581	58150	21	18*	129,3	129,0	67,8
581	58151		25			
581	58152		30			
581	58153		35			
581	58154		40			
582	58250	23	18*	141,2	142,0	73,8
582	58251		25			
582	58252		30			
582	58253		35			
582	58254		40			
583	58350	25	18*	153,2	154,0	79,8
583	58351		25			
583	58352		30			
583	58353		35			
583	58354		40			

*Plain Bore